



# ***LABELLER EASY 160***



## **INDUSTRIAL STRENGTH**

- ❖ Stainless steel fasteners and aluminium cast structure
- ❖ Operating 24/7

## **DESIGN AND STATE-OF-THE-ART TECHNOLOGY**

- ❖ Label reel housing fitted with a special inflexible fibreglass polymer disk
- ❖ Metallic black colour epoxy powder coating, scratch and corrosion proof
- ❖ Drive unit easy to open and totally accessible to guarantee quick interventions

## **VERSATILITY**

- ❖ EASY 160 can apply labels on top, bottom, in front, on the side and around the corner of the product, and is available in right or left hand versions
- ❖ Limited linear space required
- ❖ Labels reel housing available up to Ø 360 mm

## **SAFETY**

- ❖ Limited sharp edges; encased or button head screws reel housing and liner rewriter disks designed without holes for maximum safety

**CE marking (in conformity with 98/37/CE standard)**

Rev. 03-2011

## MAIN CHARACTERISTICS :

- ❖ Label reel housing diameter : External reel max. 360mm, core 45 or 75mm
- ❖ Usable liner width: Max 160 mm, Min 16 mm
- ❖ Dispensable label width: Max. 156 mm Min. 8 mm
- ❖ Minimum gap between labels: 2 mm
- ❖ Max dispensing speed : 20 meters / min (\*)
- ❖ Labelling frequency : up to 60 labels / min. ( max. 1/sec. )
- ❖ Accuracy : +/- 1 mm (\*\*)
- ❖ Power Supply : 230V - 50 Hz or 110V and 60 Hz

(\*) effective application frequency and achievable speed depend on the dimensions and materials used for the labels and liners, gap between products, and type of peeler/aplicator installed.



At maximum speed, minimum interaxis (A) between products 334 mm and minimum distance between peeler and product detection photocell 170 mm

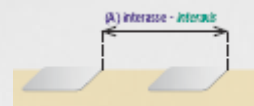

(\*\*) with a standard rigid peeler and state-of-the-art labels, contained within  $\pm 1$  mm.

The machine frame includes:

- ❖ a lighted command button with alarm reset and test dispensing functions
- ❖ 3 multi-turn gain potentiometers with a mechanical block, for setting the labelling speed, labelling point (application delay) and pre-dispensing

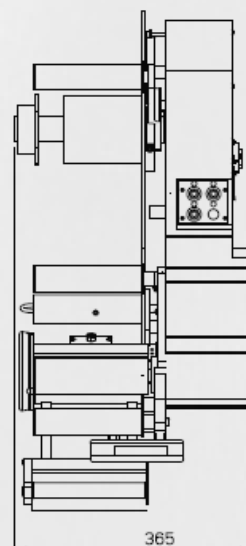
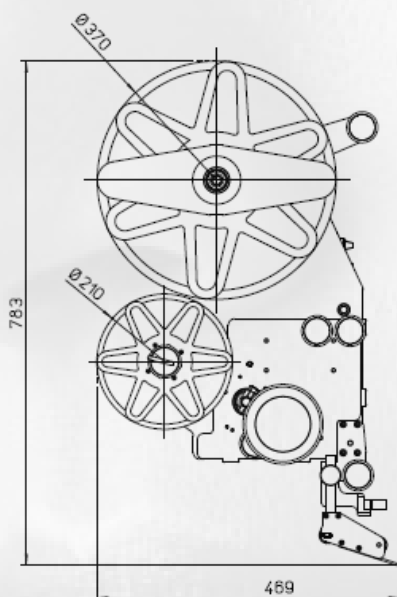

**Available with Various Supports, Adjustments, Applicators.....**



ARCA ETICHETTE SPA – 20010 MARCALLO (MI) ITALY – VIA EDISON, 119 ph. +39 02 97231.1 fax. +39 02 9761633