

Application

The universal rotation feeder for CDs, CD cards, brochures, catalogues, sachets, samples, a.o.
Integration in consignment plants, in logistic and warehouse branches

Technical Data	
Performance (depending on product)	max. 100 cycl./min (Triple head) max. 400 cycl./min (Fourfold head)
Power supply	400 V / 50 Hz, 4,5 kVA
Control unit	PLC control

Products	
Formats	min. 100 x 70 mm max. 250 x 210 mm
Paper weight	min. 250 g/m ² / Single sheet
Product thickness	1 – 10 mm

Standard Characteristics

- Feeding width 250 mm Standard
- Feeding velocity max. 100 cycles/min.
- Feeding of CDs, sachets and samples
- Suction feeder with triple head, star-shaped; optional fourfold head
- Inclined autoloader: 1000 mm + angled magazine 200 mm
- Drive by means of AC servo motor
- Single product feeding
- Separation by lift and turn movement, stroke distance 10 mm
- Building vacuum air by means of vacuum ejectors with vacuum control
- Missing sheet control by means of vacuum control
- Immediate stop when missing sheet error occurs
- Minimum stack control in magazine
- Operator guidance and status display by means of touchscreen with display
- Error warning by means of signal lamp and display text.
- Connectivity: remote control with PC, Tablet PC or Smartphone with iOS or Android (WLAN / LAN)
- Protection cover over the rotative gripper (optional)
- Pedestal (optional)



Equipment with pedestal and fourfold head (optional)

Further details see backside

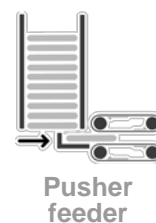
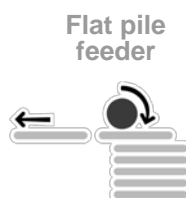
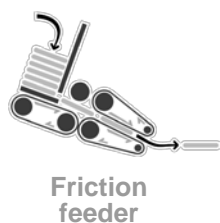

Technical Data (Standard configuration)

Format range (Special formats possible):	min. 100 x 70 mm, max. 250 x 210 mm (long edge guiding)
Velocity/feeding performance (depending on product):	max. 100 cycles/min (Triple head) max. 400 cycles/min (Fourfold head)
Product thickness:	min. 1 mm, max. 10 mm, paper quality min. 250 g/m ² , depending on product
Magazine (depending on product):	Standard 1000 mm, inclined autoloader + 200 mm angled magazine
Drive:	AC servo motor, infinitely controllable
Control unit:	PLC control: counter function; day counter; protective type IP42; graphic display with touchscreen; function for self-diagnosis, error warning, parameter setting, selectable user language (D, GB, F standard), etc.
Power supply / Power consumption:	400 V / 50 Hz, 4,5 kVA
Pressure air:	6 bar dry, oil-free air, connection ¼ ", air consumption 1000 l/min (w. 3 vacuum ejectors)
Dimensions (L x W x H) / Weight:	1,835 x 974 x 730 mm (standard version with 1000 mm autoloader), approx. 200 kg, (Version acc. to layout drawing)
Sound level:	Max. 78 dB (A), with air pressure 6 bar

Dimensions

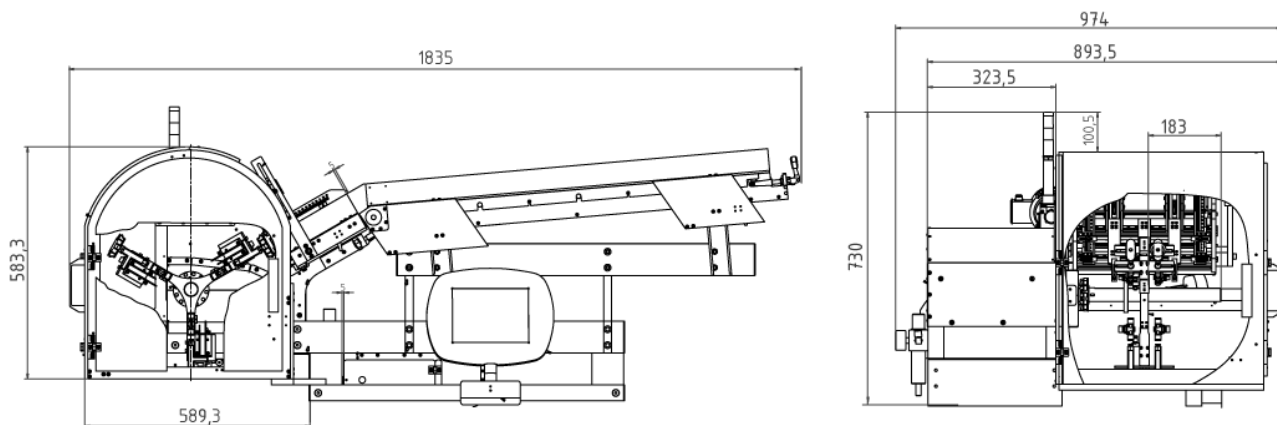

Layout with triple head

Options (depending on product)

Magazine / Loading

Magazine length 2,000 mm / 3,000 mm

Control / Monitoring

Signal lamp up to 3 colours

Level control in horizontal magazines

Integration of peripheral devices

Depending on customer application

Separation

Electrostatic discharge unit for foil products

Outfeed belt – conveyor technique

Stacking tray, adjustable to variable formats

Connectivity

Remote control via PC, Tablet PC or Smartphone (WLAN / LAN)

Other accessories / options

Electric lift pedestal for height adjustment

Predefined wear parts kits

Start sensor

Customized versions on request

